



WINDOW TECHS



A NEW WORLD
OF CARE &
COMMUNICATION



NURSE CALL SYSTEM
PRODUCT GUIDE

NURSING SUPPORT SYSTEM



WINDOW TECHS - A LEADING COMPANY IN SERVICES OF NURSE SUPPORT SYSTEM.

Window Techs is a formidable player in innovation and service in Healthcare sector from last 25 years. After joining hands and becoming an exclusive channel partner of CARECOM Co., Ltd. - A leading company of the Nursing Support System Industry with 60 years of history and experiences in Japan. As the largest market share holding company in Japan. Now, WINDOW TECHS provides not only outstanding summit technology Nurse Call Systems but also Nursing Support Solutions and Systems for efficient nursing care and patient safety widely used in hospitals.

BCRC SERIES

Interactive Nurse Call, Providing a Hotline between Nurses and Patients

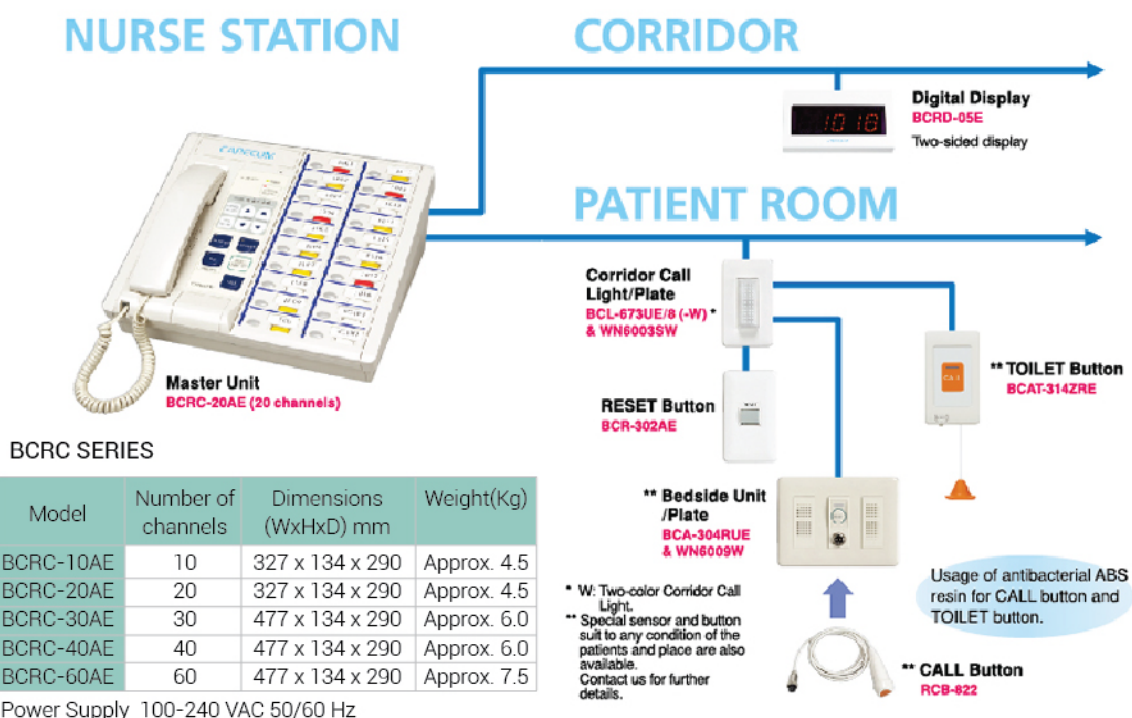

CONVENIENT USAGE OF NURSE CALL FUNCTION

Volume Control Function Five independent volume levels to suit the conditions of each patient.

Call Sounds Selectable Function The call sound can be selected from ten different melodies & chimes.

Different Call Sound Function for Emergency Call

Automatic Restore Function when Receiver Left off the Hook The unit will be restored to the standby mode for receiving general calls after ten seconds if the receiver is left off the hook. However, emergency calls can be received at all times.

CARE MANAGEMENT FUNCTION EVEN MORE CONVENIENT CARE SERVICES FOR PATIENTS

Care Level Display Function Displays patient's information in three colors in addition to the patient room number. Color-coding Information allows nurses to provide swift and individual responses. This enables immediate response during earthquakes and other emergencies.

Area Zone Display Function Displays the area zone of patients room with area zoning sticker.

Nurse Team Setup Function This function sets up and changes the master unit's call sounds by nurse teams. A maximum of five different team settings are possible.

Call Report Function

Connecting the system to a personal computer and specifying the required period and room number enables the patient's call report to be sorted and extracted.

Communications between Nurses and Hospital Staff

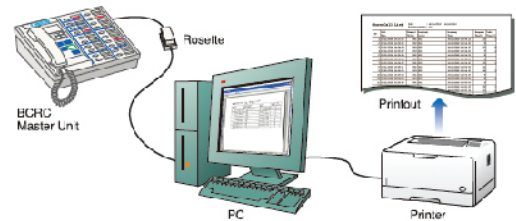
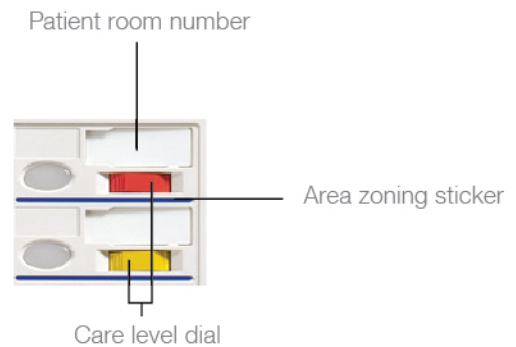
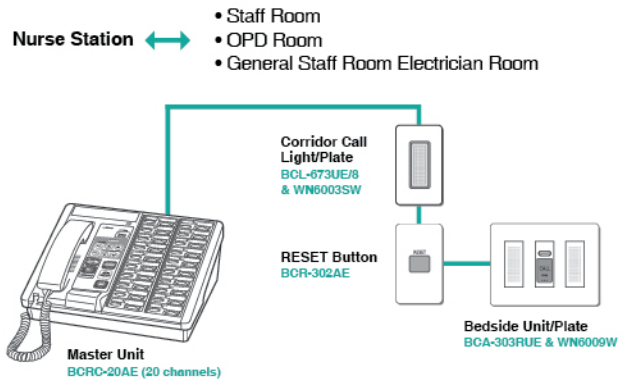

ICRC NURSE CALL (BASIC NURSE CALL)

ICRC Series

Calls from patients are notified with a call sound and call light.

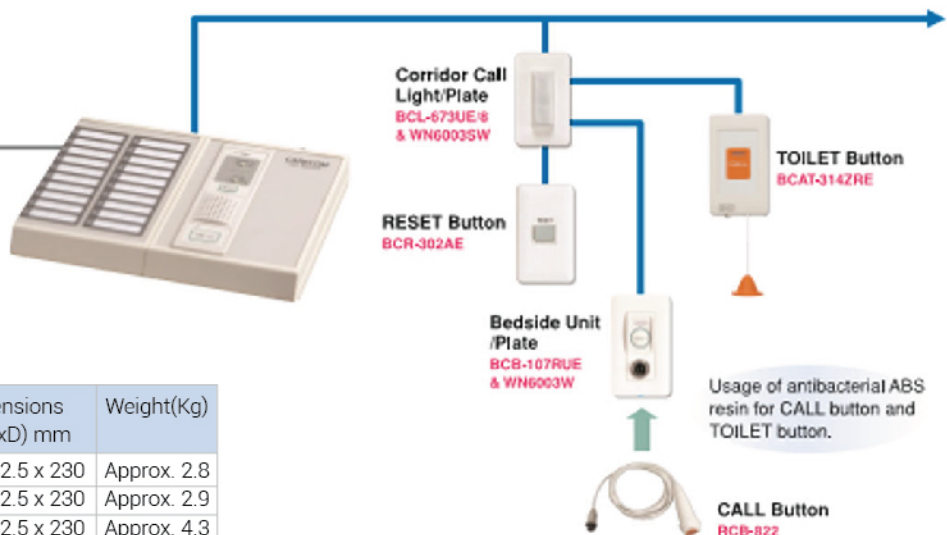

ICRC SERIES

Model	Number of channels	Dimensions (WxHxD) mm	Weight(Kg)
ICRC-10E	10	340 x 82.5 x 230	Approx. 2.8
ICRC-20E	20	340 x 82.5 x 230	Approx. 2.9
ICRC-40E	40	510 x 82.5 x 230	Approx. 4.3

Power Supply 100-240 VAC 50/60 Hz

BCAC SERIES

BCAC NURSE CALL & CARE MANAGEMENT SYSTEM BRINGS NURSES AND PATIENTS CLOSER



Patients need to be able to call a nurse anytime and get immediate attention.

Nurses need to instantly determine the condition of a patient who calls, and to give prompt, appropriate treatment. BCAC nurse call & care management system to meet both of these needs.

That's why Prime Techno Med Solutions BCAC nurse call & care management system can contribute toward earning JCI and TEMOS certification.

PATIENT SAFETY

Nurses need to respond flexibly to individual patients depending on their particular condition. Our products provide various functions to support nursing that keeps patients safe.

Sounds, colors and icons enable intuitive judgment of patient call status.

Audible and colored indicators on the master unit enable nurses to check things intuitively by sound and sight, from the patient's room number to the call situation. Nurses can also tell immediately from the various icons on the LCD whether a call is general or an emergency, or if a cord has fallen out or an intravenous drip finished. This helps them to respond appropriately even when busy.

Nurses can check the state of patients and rooms at a glance.

Information such as the condition of the patient, the state of the room, or the type of nursing being given can be color-coded using the four-color care level dial. Operation can be set up to meet different situations. This allows effective response to emergency situations such as fire or earthquake.

Intravenous drips can be checked even from a nurse station.

Nurses can tell whether an intravenous drip has finished even when they are away from the patient's room, in their nurse station or the corridor, giving both nurses and the patient a greater sense of security. Linking the system to medical equipment also enables safe monitoring of the patient's condition.

Even patients unable to push a button can call a nurse.

Our unique care sensor gives patients with muscular dystrophy or ALS the peace of mind of being able to call a nurse by just blowing, speaking, touching, or waving a hand. A mat sensor is also available to notify staff that a patient has left his or her bed.

A full history of calls by each patient can be recorded.

Analyzing historical data such as call frequency by room or by time can help to provide even better nursing.

USER FRIENDLY

Nurses need to respond flexibly to individual patients depending on their particular condition. Our products provide various functions to support nursing that keeps patients safe.

The patient-friendly design has an easy-to-find call button.

The large CALL button is attached to an orange cord and has a night light function, making it easy for the patient to find even after lights-out.

The bottom of the CALL button unit is made of non-slip rubber.

The CALL button is made of antibacterial resin to help prevent infection.

Even patients unable to push a button can call a nurse.

Our unique care sensor gives patients with muscular dystrophy or ALS the peace of mind of being able to call a nurse by just blowing, speaking, touching, or waving a hand.

A mat sensor is also available to notify staff that a patient has left his or her bed.



FOR THE FUTURE

More effective, more efficient.

Want to expand your current system to increase patient satisfaction?.

Want to make nursing more visual by adding image information and handheld terminals?.

Window Techs will fully support you in rebuilding your system toward such a future. Please feel free to consult with us.

Window Techs visual communication provides clarity at a glance.

Nurses can immediately read the situation from the call sounds, colored indicators and LCD on the master unit. The unique and various icons on the LCD let nurses know the detailed situation at a glance. This is part of how Prime Techno Med solutions is working to make nursing more visual.

General calls are shown by a yellow icon and flashing indicator.



Presence is shown by a green light-on indicator.



Emergency calls are shown by a red icon and flashing indicator.



Other types of special sensors & buttons are also available

Prime Techno Med Solutions have continued to market products that cater directly to the requirements of all people working in healthcare facilities and their patients.

One of these products is the Care Sensor, designed for patients who are not physically able to press buttons.

Our line-up at Carecom includes a wide range of special sensors and buttons to provide the peace of mind begin in touch at all times to all patients



Care sensor RCB-780E

In early 1990's with extensive experience in Custom Curtains & Rail Systems, Vishal Khandelwal's ardent desire was to bring to the Indian Hospital domain, products which shall be envy of the Global Players.

Thus, was born of WINDOW TECHS. His craving for innovation resulted in introduction for the first time in India.

His vision of MAKE IN INDIA was result of this effort.

Diversifying into allied Industries today, Window Techs is a formidable player in Hospital, Hospitality, Commercial and Residential Property domain.

Window Techs presence is not only Pan India with its dedicated team of Channel Partners, Offices and Franchisees, they have also gone global with presence in more than 20 countries in Africa, Europe, Middle East to name a few.

Having its manufacturing base in Faridabad - Haryana, India. The company today offers a strong product profile of Curtains, Curtain Tracks, IV Hangers, Wall Protection Systems, Insulated Glass Blinds, Fire Curtains Nurse Call System & Pneumatic Tube Systems.

So, when it comes to Hospital Critical System needs, trust only WINDOW TECHS.



AN ISO 9001:2015 &
ISO 13485:2012
CERTIFIED COMPANY



WINDOW TECHS INDIA PVT. LTD.

 PLOT NO. 805, Sector - 69, IMT Faridabad - 121004, Haryana.

 +91 99588 03531, +91 129 4031093

 www.windowtechs.co.in  vishal@windowtechs.in